



COMETAL®

DELTA FORMWORK



TABLE OF CONTENTS

Front cover	pag.1
Table of Contents	pag.2
Delta panel	pag.3
Tie holes Delta panel	pag.4
Corners Delta + Tie holes	pag.5
Delta accessories	pag.6
Delta general	pag.13



Technical sheet

Delta formwork

Description / principle drawing / picture	Article number	Weight
Standard panel 2400 x 1200mm Delta	DWA240120	79,84 kg
Standard panel 2400 x 600mm Delta	DWA240050	47,50 kg
Standard panel 2400 x 400mm Delta	DWA240040	36,72 kg
Standard panel 1200 x 1200mm Delta	DWA120120	44,09 kg
Standard panel 1200 x 600mm Delta	DWA120060	25,63 kg



Technical sheet

Delta formwork

Deltapaneel 2400X1200

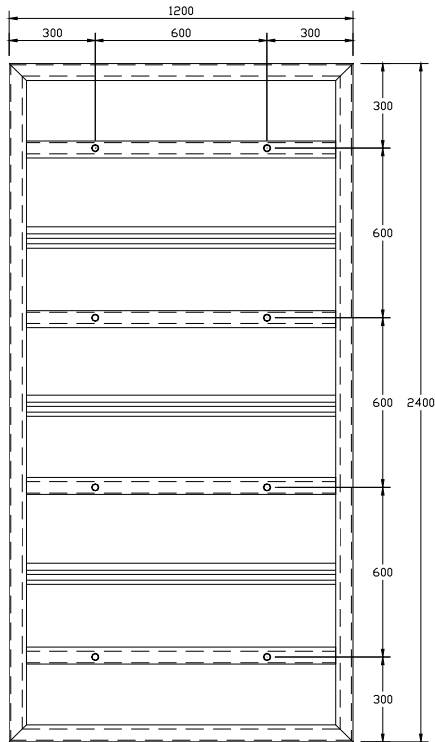

Deltapaneel 2400X600

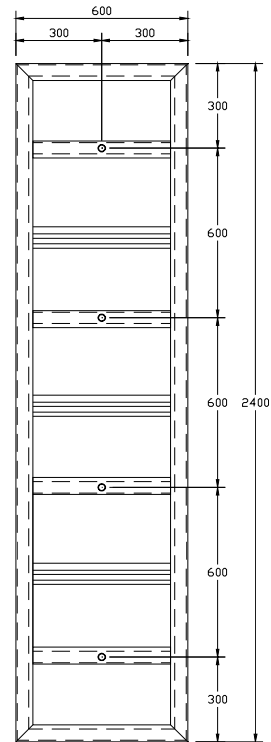

Deltapaneel 2400X400

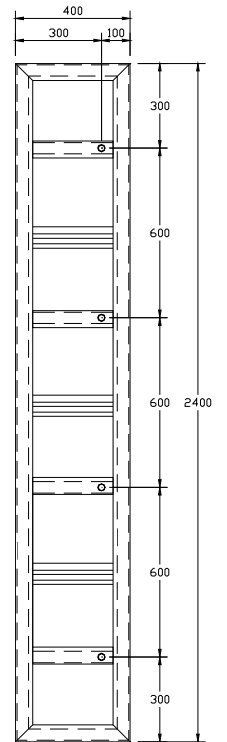

Deltapaneel 1200X1200

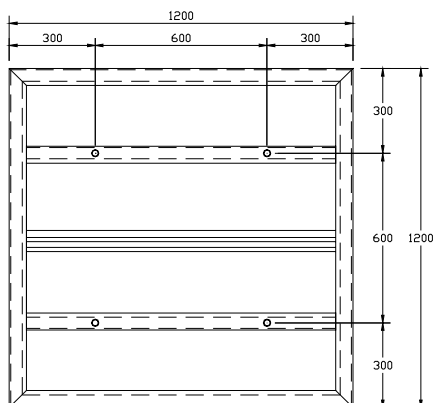

Deltapaneel 1200X600

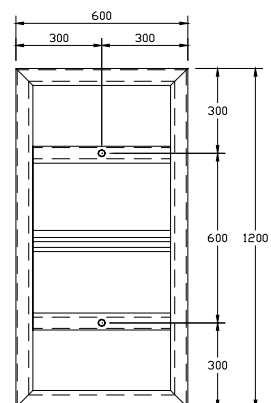

Technical sheet



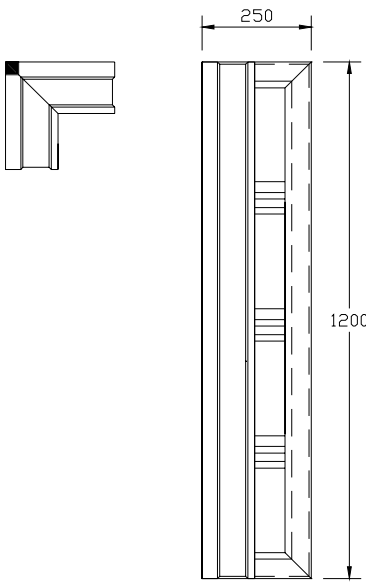
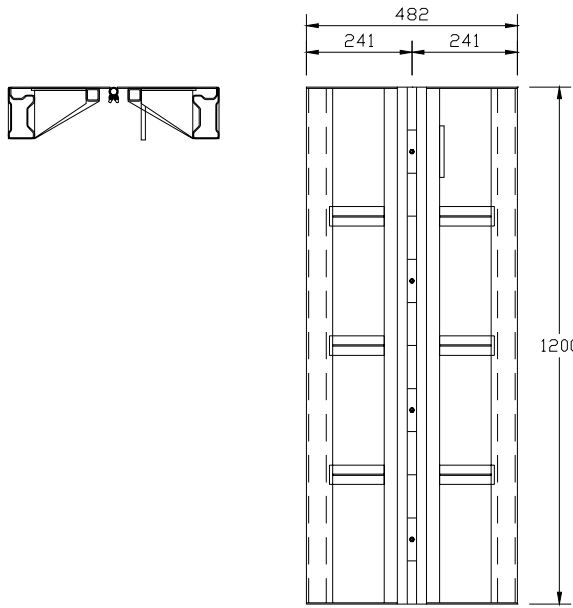
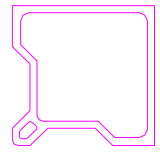

Delta formwork

Description / principle drawing / picture	Article number	Weight
<p>Corner panel 1200 x 250 x 250mm Delta</p> 	ABI120025	19,00 kg
<p>Corner panel art. 1200 x 250 x 250mm</p> 	SBI120025	48,00 kg
<p>Outer corner profile Alu. 2400mm Outer corner profile Alu. 1200mm</p> 	ABP240 ABP120	20,37 kg 10,31 kg



Technical sheet





Delta formwork

Article number	Description / principle drawing / picture	Weight
KLE001	RAPID ALIGNMENT COUPLER RIGHT 	3,00 kg
KLE002	RAPID ALIGNMENT COUPLER LEFT 	3,00 kg
KLE003	COMPENSATION COUPLER SHORT 	3,37 kg
KLE004	COMPENSATION COUPLER LONG 	4,61 kg



Technical sheet



Delta formwork

Article number	Description / principle drawing / picture	Weight
KLE008	BASE COUPLER 	1,695 kg
KLE009	ATTACHMENT WEDGE CPL 	0,63 kg
KLE010	TIE ROD COUPLER DW15 	0,34 kg
KLE020	TIE ROD COUPLER DW15 ALCOM CPL 	1,16 kg



Technical sheet

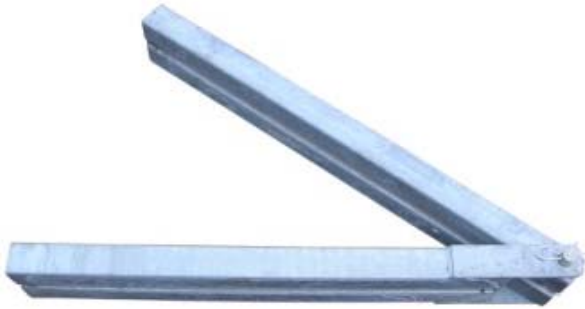



Delta formwork

Article number	Description / principle drawing / picture	Weight
<p>PBU050 PBU075 PBU100 PBU125 PBU150 PBU175 PBU200</p>	<p>COMPENSATION BEAM 0,50M COMPENSATION BEAM 0,75M COMPENSATION BEAM 1,00M COMPENSATION BEAM 1,25M COMPENSATION BEAM 1,50M COMPENSATION BEAM 1,75M COMPENSATION BEAM 2,00M</p> 	<p>4,50 kg 6,70 kg 8,89 kg 11,14 kg 13,34 kg 15,53 kg 17,73 kg</p>
<p>PSC075 PSC100 PSC125 PSC150</p>	<p>COMPENSATION TUBE ART. 0,75 X 0,75M COMPENSATION TUBE ART. 1,00 X 1,00M COMPENSATION TUBE ART. 1,25 X 1,25M COMPENSATION TUBE ART. 1,50 X 1,50M</p> 	<p>14,58 kg 18,98 kg 23,42 kg 27,81 kg</p>
<p>SPA015035 SPA015055 SPA015075 SPA015100 SPA015125 SPA015150 SPA015175 SPA015200</p>	<p>TIE ROD 15MM 0,35M 85kN TIE ROD 15MM 0,55M 85kN TIE ROD 15MM 0,75M 85kN TIE ROD 15MM 1,00M 85kN TIE ROD 15MM 1,25M 85kN TIE ROD 15MM 1,50M 85kN TIE ROD 15MM 1,75M 85kN TIE ROD 15MM 2,00M 85kN (other length also available, up to 6m)</p> 	<p>0,53 kg 0,83 kg 1,13 kg 1,50 kg 1,88 kg 2,25 kg 2,63 kg 3,00 kg</p>



Technical sheet





Delta formwork

Article number	Description / principle drawing / picture	Weight
MOE015002	WING NUT BRACKET 15MM DIA. 100MM 	0,65 kg
TOE001	PRESSION PLATE 	1,60 kg
HIJ001	CRANE LIFTING HOOK 750KG CE 	9,30 kg
HIJ011	CRANE LIFTING HOOK ALCOM 1500KG CE 	9,40 kg



Technical sheet



Delta formwork

Article number	Description / principle drawing / picture	Weight
VEI003	ALU. BRACKET DELTA 	5,85 kg
RIC001	PUSH & PULL PROP SINGLE 230 	18,80 kg
RIC002	PUSH & PULL PROP SINGLE 85 	8,00 kg
RIC003	PUSH & PULL PROP SINGLE 160 	14,40 kg



Technical sheet

Delta formwork

Article number	Description / principle drawing / picture	Weight
RIC004	<p data-bbox="624 293 1070 322"><i>PUSH & PULL PROP SINGLE LONG</i></p> 	27,50 kg
RIC005	<p data-bbox="624 1086 1102 1115"><i>PUSH & PULL PROP DOUBLE 160-230</i></p> 	33,85 kg
RIC006	<p data-bbox="624 1608 1086 1637"><i>PUSH & PULL PROP DOUBLE 85-160</i></p> 	34,00 kg



Technical sheet

Article number	Description / principle drawing / picture	Weight
RIC106	<i>HOR. BRACE CONNECTOR DELTA CPL</i> 	3,60 kg

Delta formwork



Technical sheet

Delta formwork

DELTA SYSTEM FORMWORK: MODULAR FORMWORK FOR VISIBLE CONCRETE WITH UNIFORM OPTICAL EFFECT

A DELTA panel is constructed from a top quality aluminium framework with a high quality concrete multiplex made from exotic hardwood, provided with a coating of 450 gr/m². Specific to DELTA is that all seams and end holes are located at a set distance from each other. This results in a unique repetitive pattern of panel seams and end holes in the visible concrete. A matrix of 600 mm was opted for, in which the uniform hole pattern follows a grid of 600 x 600mm. The standard DELTA panel measures 2400 x 1200mm. For technical formwork reasons panels with other measurements are also offers in addition to the standard DELTA panel. The DELTA system formwork was developed at the request of the architectural sector as a solution for visible concrete poured on site with a uniform optical effect.

Detailtekeningen Deltabekisting met hoogte 3 x 1m20 horizontaal

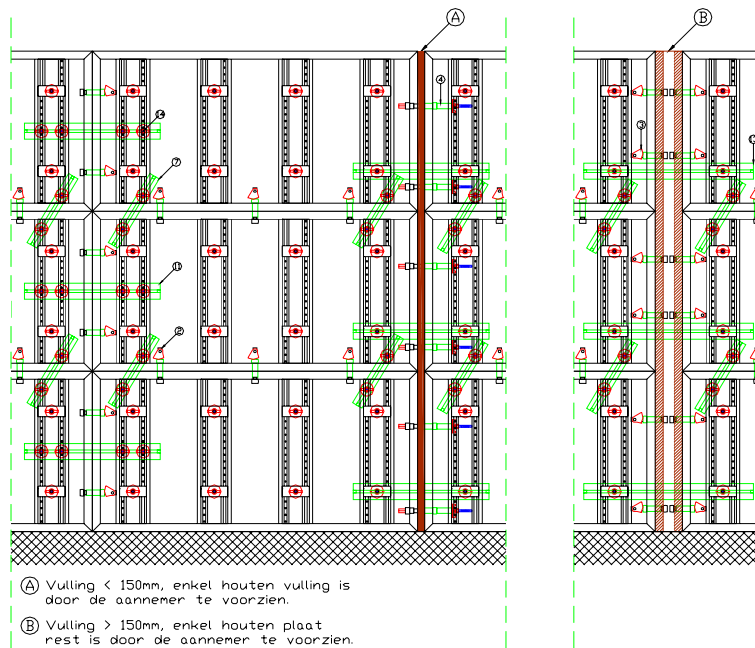

- Ⓐ Vulling < 150mm, enkel houten vulling is door de aannemer te voorzien.
 Ⓑ Vulling > 150mm, enkel houten plaat rest is door de aannemer te voorzien.

