



COMETAL®

CLIMBING FORMWORK



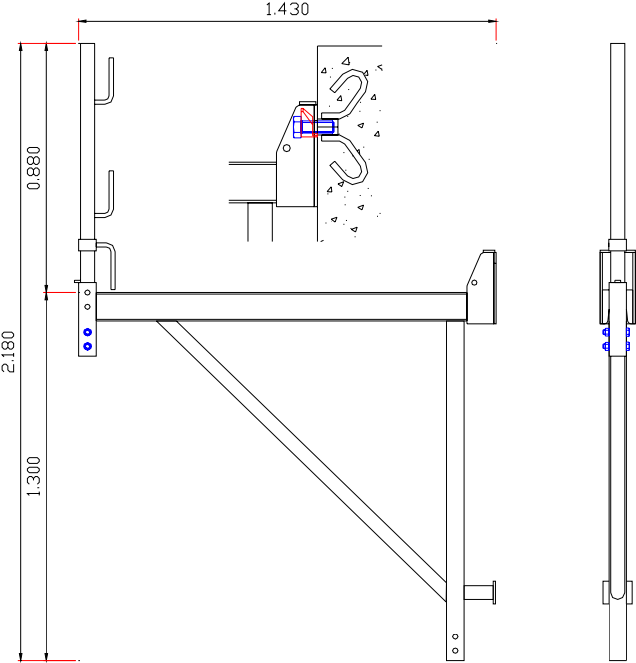

TABLE OF CONTENTS

Front cover	pag.1
Table of Contents	pag.2
Brackets 1.40m cpl.	pag.3
Fixation brackets 1.40m	pag.5
Bracket 2.40m cpl. without hinge	pag.5
Wall scaffold hinge system 2.40m cpl.	pag.9
Attachment of bracket 2.40m	pag.10



Technical sheet





Bracket 1.40m cpl.

Article number	Description / principle drawing / picture	Weight
<p>KL1140001</p>	<p>Composite article BRACKET 1.40M CPL.</p>  <p>High sides are poured in multiple steps. In that case layers are poured and one climbs up on the formwork. From the second layer the formwork is constructed on brackets. The 1m40 bracket has a walking area 1m40 wide. This is used in formwork with single height or on sites where there is little place. The 1m40 bracket must be provided as a min. every 2m40.</p>	<p>36,20 kg</p>
<p>KL1140101</p>	<p>Parts of composite article BRACKET 1.40M (1 unit required per bracket 1.40m Cpl.)</p> 	<p>31,00 kg</p>



Technical sheet

Bracket 1.40m cpl.

Article number	Description / principle drawing / picture	Weight
KL1140102	Parts of composite article HANDRAIL CLIMBING BR. 1,40M (1 unit required per bracket 1.40m Cpl.) 	5,20 kg
KL1140103	Parts of composite article WEDGE FOR CLIMBING BR.1,40M (1 unit required per bracket 1.40m Cpl.) 	0,34 kg
FAB016080	Parts of composite article HEXAGON HEAD BOLT 8.8 M16X80 Z (2 units required per bracket 1.40m Cpl.) 	0,16 kg
FAT030070	Parts of composite article HEXAGON HEAD SCREW 8.8 M30X70 Z (1 unit required per bracket 1.40m Cpl.) 	0,59 kg
FAO016	Parts of composite article HEX. SECURITY NUT M16 Z (2 units required per bracket 1.40m Cpl.) 	0,03 kg



Technical sheet

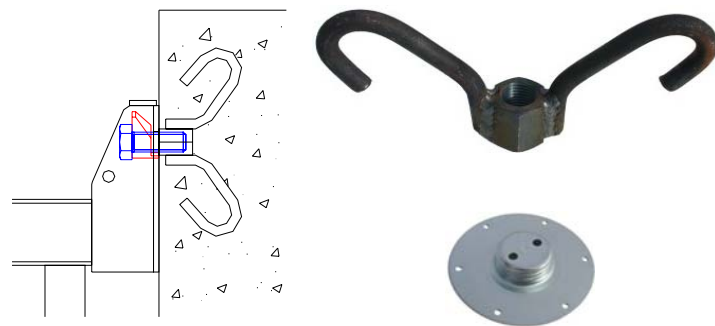
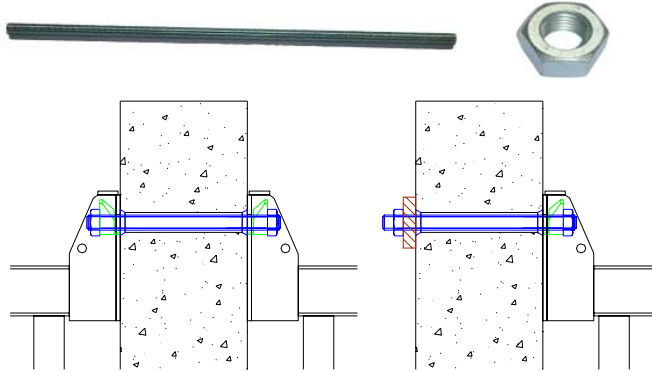
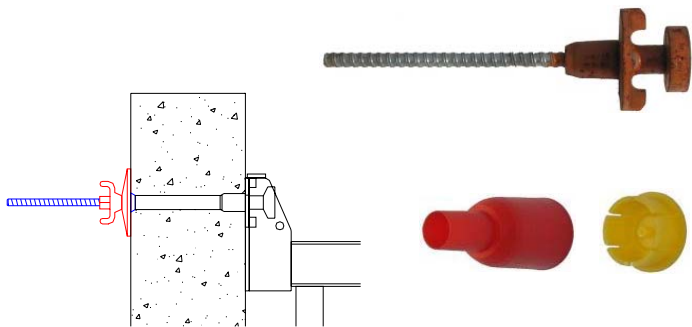

Fixation bracket 1.40m cpl.

Article number	Description / principle drawing / picture	Weight
Purchase KLI140002 KLI140003	CLIMBING ANCHOR M30 WITH PLUG NAILING PLATE M30 	1,21 kg 0,01 kg
Purchase FAD030100 FAM030 DRS032038 DDK032	THREADED ROD M30 1000MM HEXAGON NUT M30 Z THRUTY SLEEVE 32/38 (50m) THRUTY CONE 32 (500pc) 	4,75 kg 0,22 kg 0,38 kg 0,01 kg
Rental KLI140005 MOE015004 Purchase DMK001 DMK002	KOMBI ADAPTER FB70 DW15 COMINATION PLATE DW15 CONE "MANTELPIJP" PLUG "MANTELPIJP" 	2,60 kg 1,42 kg 0,02 kg 0,01 kg



Technical sheet

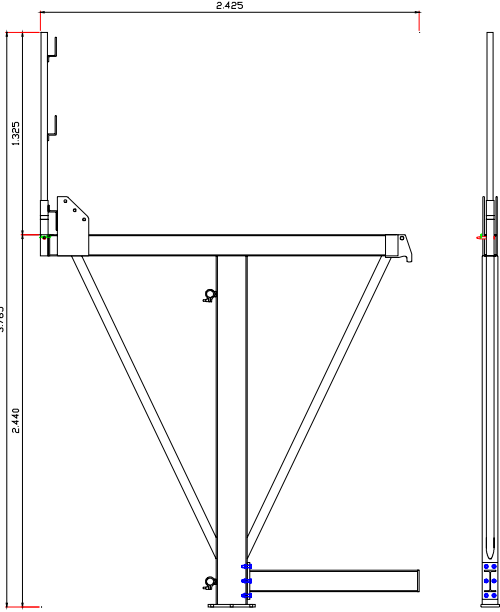



Bracket 2.40m cpl. Without hinge

Article number	Description / principle drawing / picture	Weight
<p>KL1240001</p>	<p>Composite article BRACKET 2.40M CPL. WITHOUT HINGE</p>  <p>High sides are poured in multiple steps. In that case layers are poured and one climbs up on the formwork. From the second layer the formwork is constructed on brackets. The 2m40 bracket has a walking area 2m40 wide. This is used in formwork with multiple heights or on sites where there needs to be more space for movement. The 2m40 bracket must be provided as a min. every 2m40.</p>	<p>150,00 kg</p>
<p>KL1240101</p>	<p>Parts of composite article BRACKET 2.40M (1 unit needed per bracket 2m40 Cpl. without hinge)</p> 	<p>125,00 kg</p>



Technical sheet

Bracket 2.40m cpl. Without hinge

Article number	Description / principle drawing / picture	Weight
KL1240102	<p>Parts of composite article HOR. SUPPORT CL. BRACKET 2,40M (1 unit needed per bracket 2m40 Cpl. without hinge)</p> 	18,00 kg
KL1240103	<p>Parts of composite article HANDRAIL CLIMBING BR.2,40M (1 unit needed per bracket 2m40 Cpl. without hinge)</p> 	6,25 kg
TBP003	<p>Parts of composite article SPRING COTTER 3MM DOUBBLE (1 unit needed per bracket 2m40 Cpl. without hinge)</p> 	0,001 kg
TPP015	<p>Parts of composite article CONNECTING PIN 15MM (1 unit needed per bracket 2m40 Cpl. without hinge)</p> 	0,15 kg
FAT016040	<p>Parts of composite article HEXAGON HEAD SCREW 8.8 M16X40Z (6 units needed per bracket 2m40 Cpl. without hinge)</p> 	0,09 kg



Technical sheet





Bracket 2.40m cpl. Without hinge

Article number	Description / principle drawing / picture	Weight
FA0016	<p>Parts of composite article HEX. SECURITY NUT M16Z (3 units needed per bracket 2m40 Cpl. without hinge)</p> 	0,03 kg
FAB016040	<p>Parts of composite article HEXAGON HEAD SCREW 8.8 M16X40Z (3 units needed per bracket 2m40 Cpl. without hinge)</p> 	0,22 kg

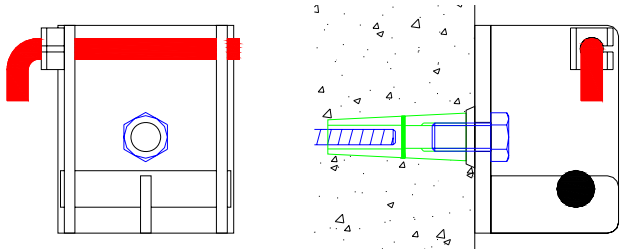

Technical sheet

Wall scaffold hinge system 2.40m cpl.

Article number	Description / principle drawing / picture	Weight
KL1240011	<p>Composite article WALL SCAFFOLD HINGE SYSTEM 2.40M CPL.</p>  <p>The wall scaffold hinge system 2.40 Cpl. Is a practical and quick wall hinge system for the bracket 2.40m. It is possible through the design of the hinge to hang the bracket very easily. 50 mm horizontal play is provided so that the anchor to be poured in can be realised smoothly The safety pin ensures that the bracket does not come out of the hinge. 2 wall scaffold hinge systems should be provided per bracket, 1 cm hanging in and 1 header hinge.</p>	9,98 kg
KL1240002	<p>Parts of composite article WALL SCAFFOLD HINGE SYSTEM 2.40M separate (1 unit required per wall scaffold hinge system 2.40 cpl.)</p> 	8,80 kg
KL1240003	<p>Parts of composite article CONE 33/46 130MM DW20/M27 (1 unit needed per wall scaffold hinge system 2.40m cpl.)</p> 	0,78 kg
FAT027055	<p>Parts of composite article HEXAGONAL BOLT 8.8 M27X55 galv. (1 unit needed per wall scaffold hinge system 2.40m cpl.)</p> 	0,40 kg



Technical sheet

Attachement of bracket 2.40m cpl.

Article number	Description / principle drawing / picture	Weight
Rental KLI240006 KLI240005 Purchase FAD027100 DRS032038 DDK032	BRACKET NUT 8.8 M27 NUT M27X330 8.8 (maximum wall thickness 250mm) THREADED ROD M27 1M (to be cut to size by contractor) TUBE 32/38 PVC (packed per 50m) PRESSURE CONE 32 (packed per 500units)	0,50 kg 3,85 kg 0,38 kg 0,01 kg
Purchase SPA020..... KLI240004	TENSIONING ROD DW20MM (wall thickness - 150mm) NAIL PLATE PVC 60/8MM M27 (minimum wall thickness 300mm)	/ 0,01 kg
Purchase SPA020..... KLI240004 KLI240015	TENSIONING ROD DW20MM (wall thickness - 140mm) NAIL PLATE PVC 60/8MM M27 FIXING ANCHOR 20MM (minimum wall thickness 250mm)	/ 0,01 kg 0,85 kg

